



Model Number

EVM58-TZ

Features

- Industrial standard housing Ø58 mm
- Ethernet interface with TCP/IP
- 30 Bit multiturn
- Integrated webserver
- Servo or clamping flange

Description

Absolute multiturn rotary encoders deliver an absolute step value for each angle setting. This device has a maximum basic resolution of 65536 steps per revolution (16 bits) and codes up to 16384 revolutions (14 bits). Thus the overall resolution amounts to 30 bits. On account of the high number of measuring steps resulting (more than 1 billion), this type of encoder can be used to divide very long linear distances into small measuring steps.

The Ethernet interface of this absolute encoder supports the TCP/IP protocol. The integrated webserver provides Java applets, which allow the whole parameterisation of the encoder via any web browser. The following operation modes can be selected:

- Polled Mode
- Cyclic Mode
- Change of State Mode

The device is designed for shaft assembly and is available in servo flange or clamping flange design.

Technical data

General specifications

Detection type	photoelectric sampling
Device type	Multiturn absolute encoder

Functional safety related parameters

MTTF _d	120 a
Mission Time (T _M)	20 a
L _{10h}	1.9 E+11 at 6000 rpm and 20/40 N axial/radial shaft load
Diagnostic Coverage (DC)	0 %

Electrical specifications

Operating voltage U _B	10 ... 30 V DC
Power consumption P ₀	max. 4 W
Linearity	± 0.5 LSB (up to 12 Bit) ± 2 LSB (up to 16 Bit)
Output code	binary code
Code course (counting direction)	programmable, cw ascending (clockwise rotation, code course ascending) cw descending (clockwise rotation, code course descending)

Interface

Interface type	TCP/IP
Resolution	
Single turn	up to 16 Bit
Multiturn	14 Bit
Overall resolution	up to 30 Bit
Physical	Ethernet
Transfer rate	10 MBit/s / 100 MBit/s

Connection

Connector	Ethernet: 1 socket M12 x 1, 4-pin, D-coded Supply: 1 plug M12 x 1, 5-pin, A-coded
-----------	--------------------------------------------------------------------------------------

Standard conformity

Degree of protection	DIN EN 60529, shaft side: IP64 (without shaft seal)/IP66 (with shaft seal) housing side: IP65
Climatic testing	DIN EN 60068-2-3, no moisture condensation
Emitted interference	EN 61000-6-4:2007
Noise immunity	EN 61000-6-2:2005
Shock resistance	DIN EN 60068-2-27, 100 g, 6 ms
Vibration resistance	DIN EN 60068-2-6, 10 g, 10 ... 2000 Hz

Ambient conditions

Operating temperature	0 ... 60 °C (32 ... 140 °F) Standard , with Option T -40 ... 85 °C (-40 ... 185 °F)
Storage temperature	-40 ... 85 °C (-40 ... 185 °F)

Mechanical specifications

Material	housing: powder coated aluminum flange: aluminum shaft: stainless steel
Mass	approx. 700 g
Rotational speed	max. 12000 min ⁻¹
Moment of inertia	30 gcm ²
Starting torque	≤ 3 Ncm (version without shaft seal)
Shaft load	
Axial	40 N
Radial	110 N

Approvals and certificates

UL approval	cULus Listed, General Purpose, Class 2 Power Source
-------------	-----------------------------------------------------

Dimensions

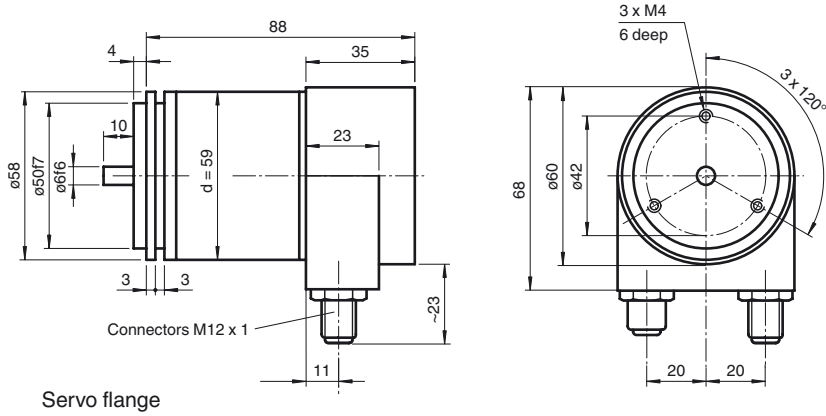

Servo flange

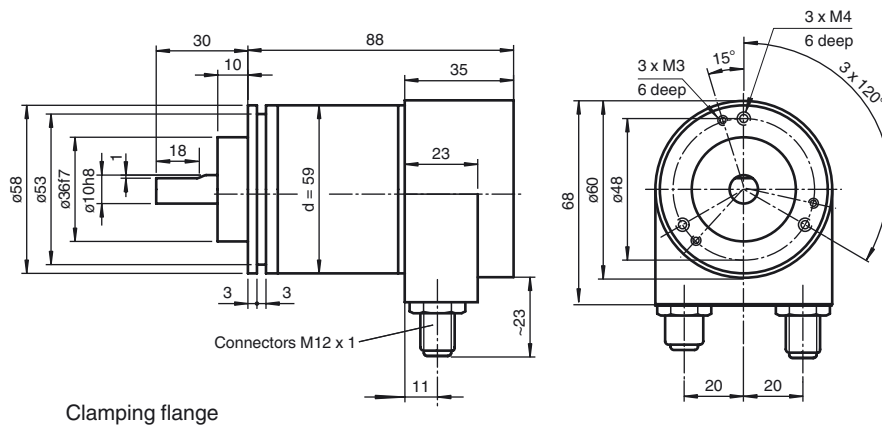

Clamping flange

Electrical connection

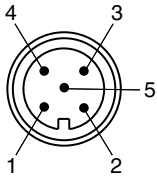
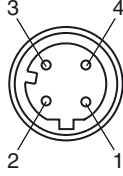
Pin	Male connector M12 x 1, 5-pin, A-coded	Female connector M12 x 1, 4-pin, D-coded
1	+ 24 V	Rx +
2	+ 24 V	Tx +
3	0 V	Rx -
4	0 V	Tx -
5	PE	
		

Indicators and operation means

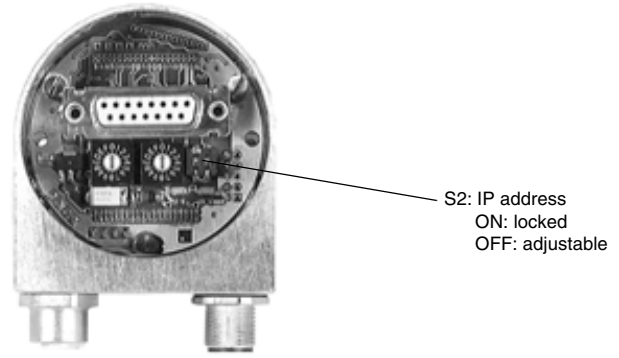
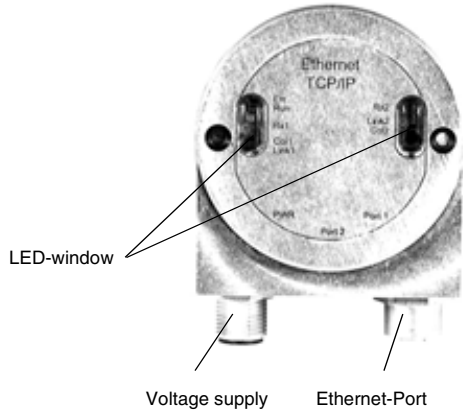

LED-indicators

LED	Colour	Meaning
Rx1	yellow	Data traffic on Port 1
Link1	green	Connection to an Ethernet device on Port 1
Col1	red	Bus collision on Port 1
Err	red	Internal error
Run	green	Ethernet interface ready to work

Set switch S2 to position OFF. The IP address can be adjusted now. In switch position ON, the IP address is blocked to avoid unintended change.

The rotary switches and switch S1 are without any function.

IP address adjustment

Accessories

Accessories	Name/defining feature	Order code	Description
Couplings	D1: Ø6 mm, D2: Ø6 mm	9401	shaft Ø6 mm
	D1: Ø6 mm, D2: Ø6 mm	9402	
	D1: Ø6 mm, D2: Ø6 mm	9404	
	D1: Ø6 mm, D2: Ø6 mm	9409	
	D1: Ø6 mm, D2: Ø6 mm	KW	
	D1: Ø10 mm, D2: Ø10 mm	9401	
	D1: Ø10 mm, D2: Ø10 mm	9404	
	D1: Ø10 mm, D2: Ø10 mm	9409	
Measurement wheels with circumference of 500 mm	Plastic	9101, 10	shaft Ø10 mm
	Pimpled rubber	9102, 10	
	Knurled aluminium	9103, 10	
	Knurled plastic	9112, 10	
Measurement wheels with circumference of 200 mm	Plastic	9108, 10	
	Pimpled rubber	9109, 10	
	Knurled aluminium	9110, 10	
	Knurled plastic	9113, 10	
Mounting aids	Mounting bracket	9203	Clamping flange
	Mounting bracket	9213	
Mounting aids	Mounting bracket and set	9300 and 9311-3	Servo flange
	Eccentric clamping elements	9310-3	

For additional information on the accessories, please see the "Accessories" section.

Order code

